

TrafficLight2 Example

A Much Better Idea : Logical : Unique



AmbiLogique

Electronic Controllers

The TrafficLight2 example builds on the simple TrafficLight1 example, and adds on-demand or conditional sequencing.

On Sheet 2 we have added Doppler approach detectors and threshold detector pads to the East-West direction. In order to favour traffic on the North-South route, E-W will remain on red until either of its approach detectors is triggered.

Note the interaction between the Doppler and Threshold detectors. We can safely assume that if a vehicle has arrived at the threshold, its Doppler trigger will no longer be required.

AmbiLogique Ltd 1812 Opunake Road, RD29, Hawera 4679, New Zealand

+64 6 764 6567 ph

www.ambilogique.com

sales@ambilogique.com

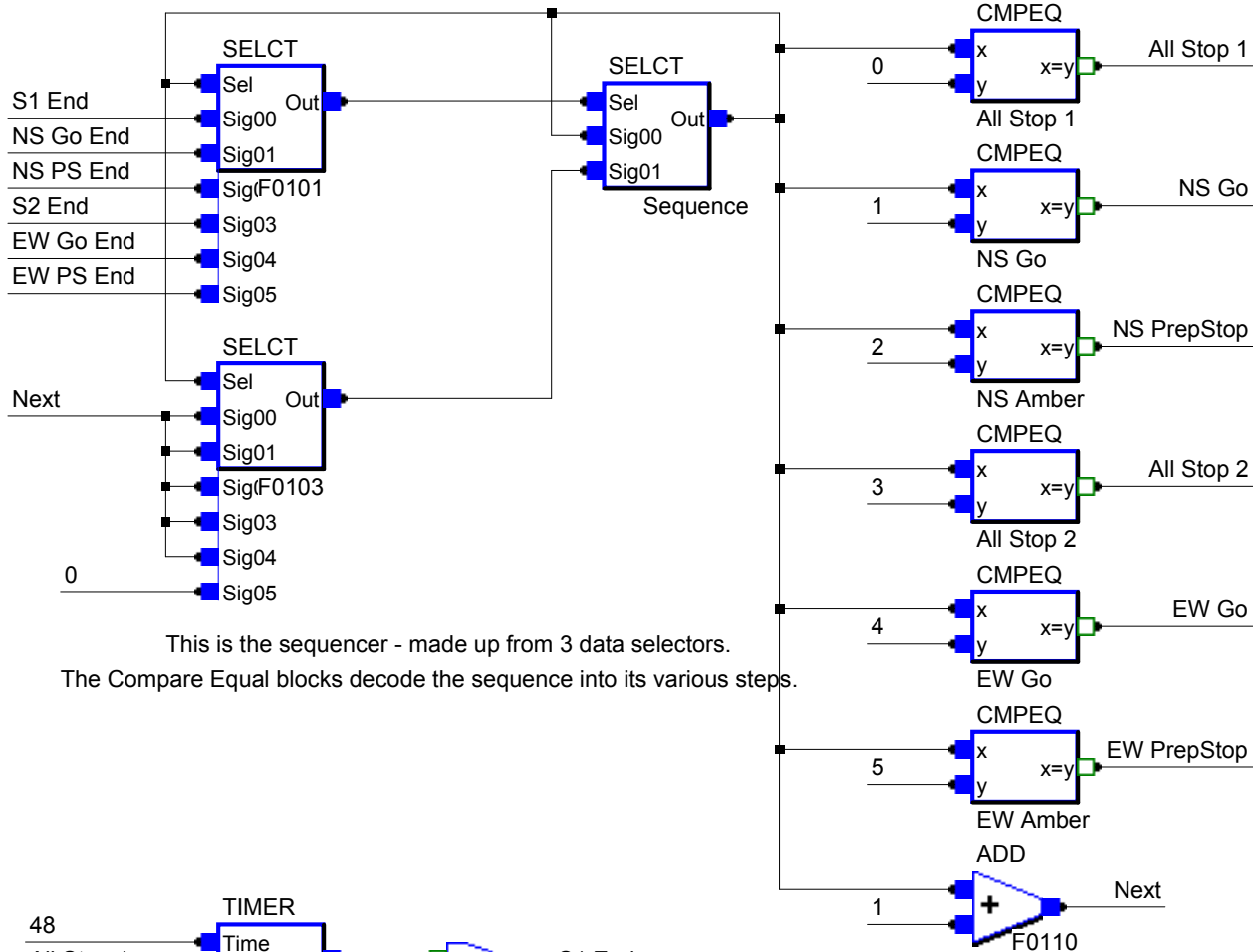

This is the sequencer - made up from 3 data selectors.
The Compare Equal blocks decode the sequence into its various steps.

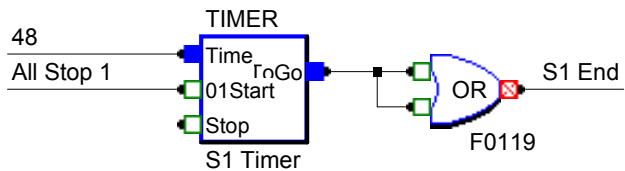

This timer sets the time for which the All Stop 1 step lasts.
The timers for the other steps are on Sheet 2.
The unwired Stop input behaves as if it did not exist.

This block generates the Next signal which determines which step the sequencer will go to when the 'End' signal is generated.
Since this sequencer always moves on to the next step, this single increment block can be used to generate the next step for every step except the last.

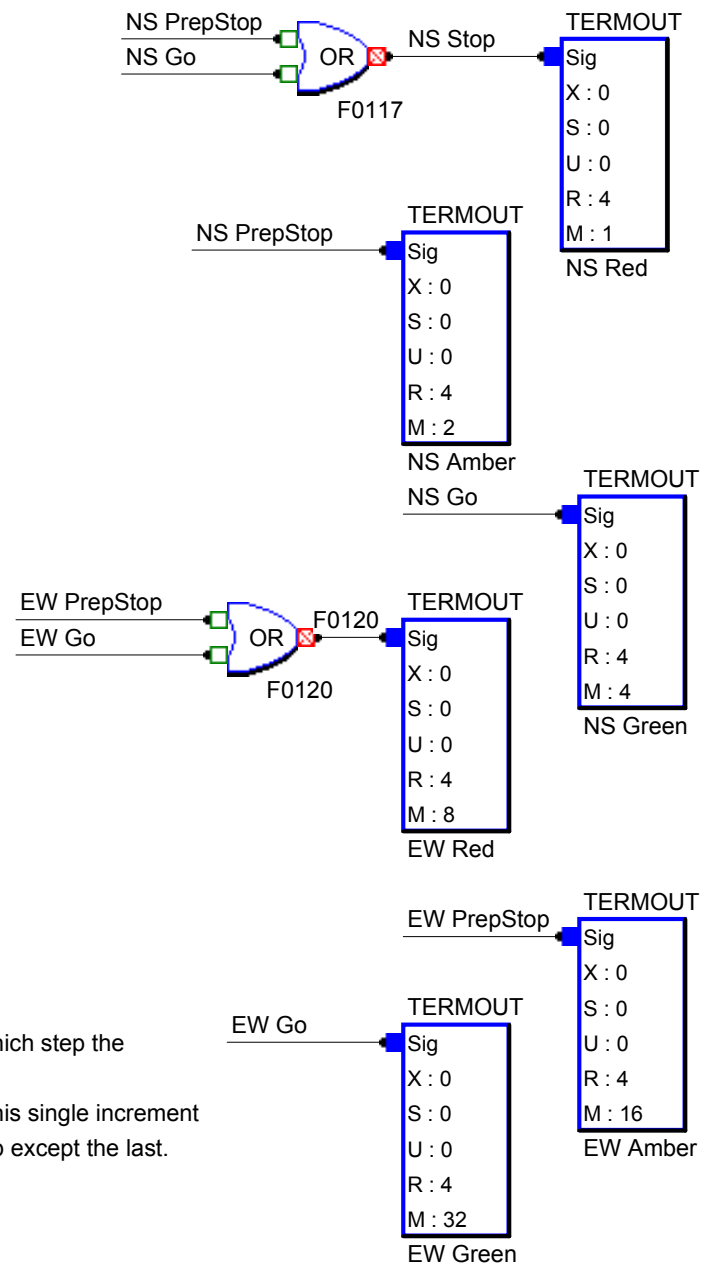

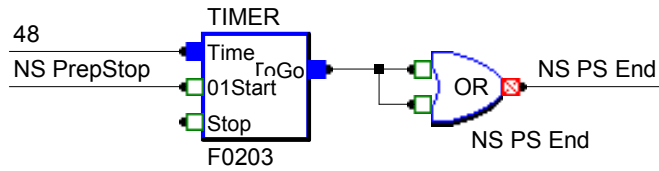

This timer is $48 / 16 = 3$ seconds. The 16 is the scan rate in Hz.

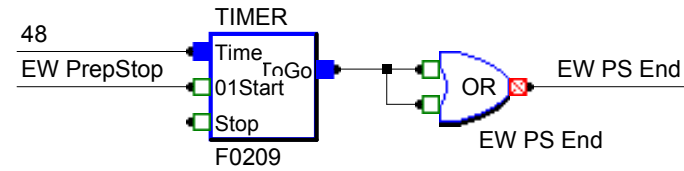
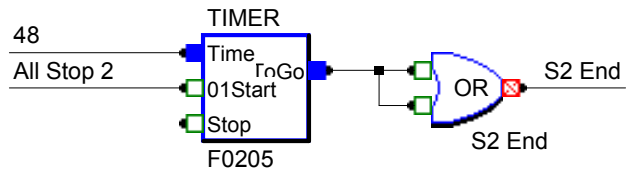
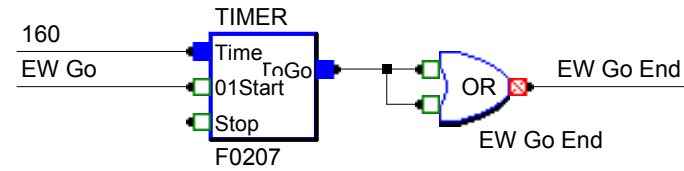

Now we decide that the NS direction is a major road.

We will only end its Go period if there is a request from the minor road after its Go timer has expired.

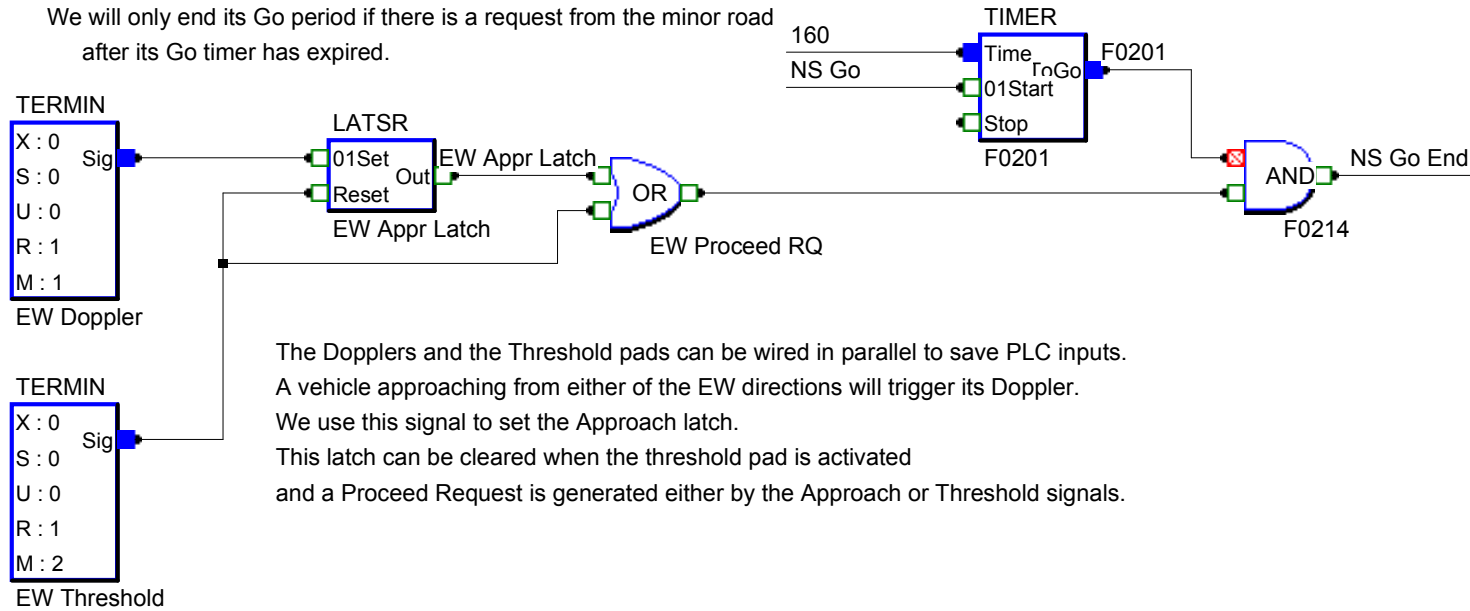

The Dopplers and the Threshold pads can be wired in parallel to save PLC inputs. A vehicle approaching from either of the EW directions will trigger its Doppler. We use this signal to set the Approach latch. This latch can be cleared when the threshold pad is activated and a Proceed Request is generated either by the Approach or Threshold signals.